



/ HAY MAZE JE OBJEKAT PRIVREMENOG KARAKTERA OSMIŠLJEN KAO LAVIRINT, MESTO SUSRETA RAZLIČITIH GENERACIJA I IZLOŽBENI PROSTOR. PREDSTAVLJA PRIMER EFEMERNE ARHITEKTURE KOJI KROZ INOVATIVNI PRISTUP OBJEDIJUJE ODRŽIVOST U ARHITEKTURI, FUNKCIONALNOST I DRUŠTVENU INTERAKCIJU.

OSNOVNI PODACI O OBJEKTU
 ДИМЕНЗИЈА ОСНОВЕ: 9.5m x 14m
 ПОВРШИНА: 133m²
 ТЕЖИНА: 7.5t
 КОЛИЧИНА БАЛА СЛАМЕ: 450

/ HAY MAZE IS A TEMPORARY STRUCTURE DESIGNED AS A LABYRINTH, A MEETING POINT FOR DIFFERENT GENERATIONS AND AN EXHIBITION SPACE. IT REPRESENTS AN EXAMPLE OF EPHEMERAL ARCHITECTURE THAT COMBINES SUSTAINABILITY IN ARCHITECTURE, FUNCTIONALITY, AND SOCIAL INTERACTION THROUGH AN INNOVATIVE APPROACH.

BASE INFORMATION ABOUT THE OBJECT
 FLOOR PLAN DIMENSIONS: 9.5m x 14m
 AREA: 133m²
 WEIGHT: 7.5t
 HAY BALES QUANTITY: 450

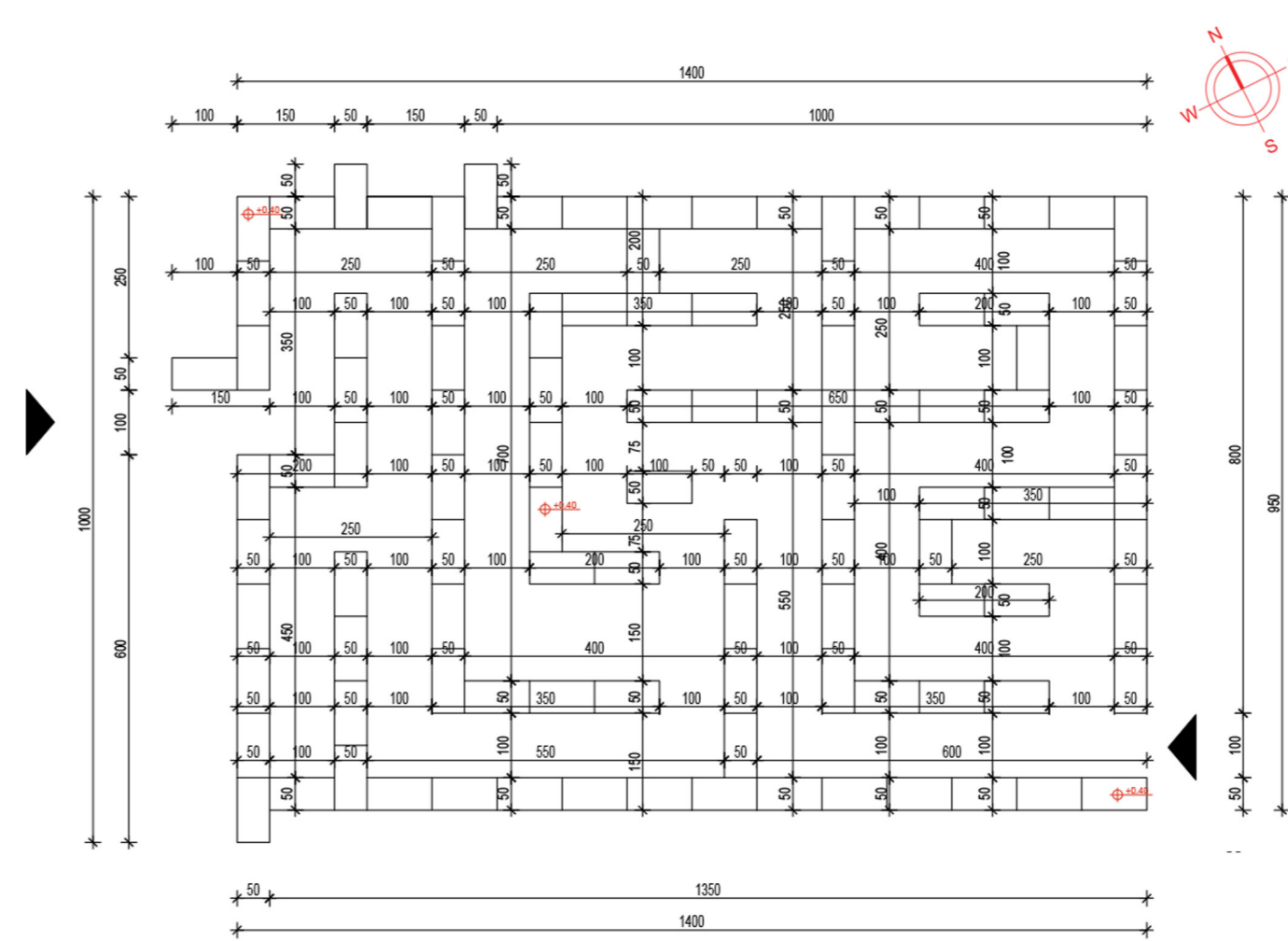

/ ОСНОВА ПРВОГ НИВОА
 / FIRST LEVEL FLOOR PLAN

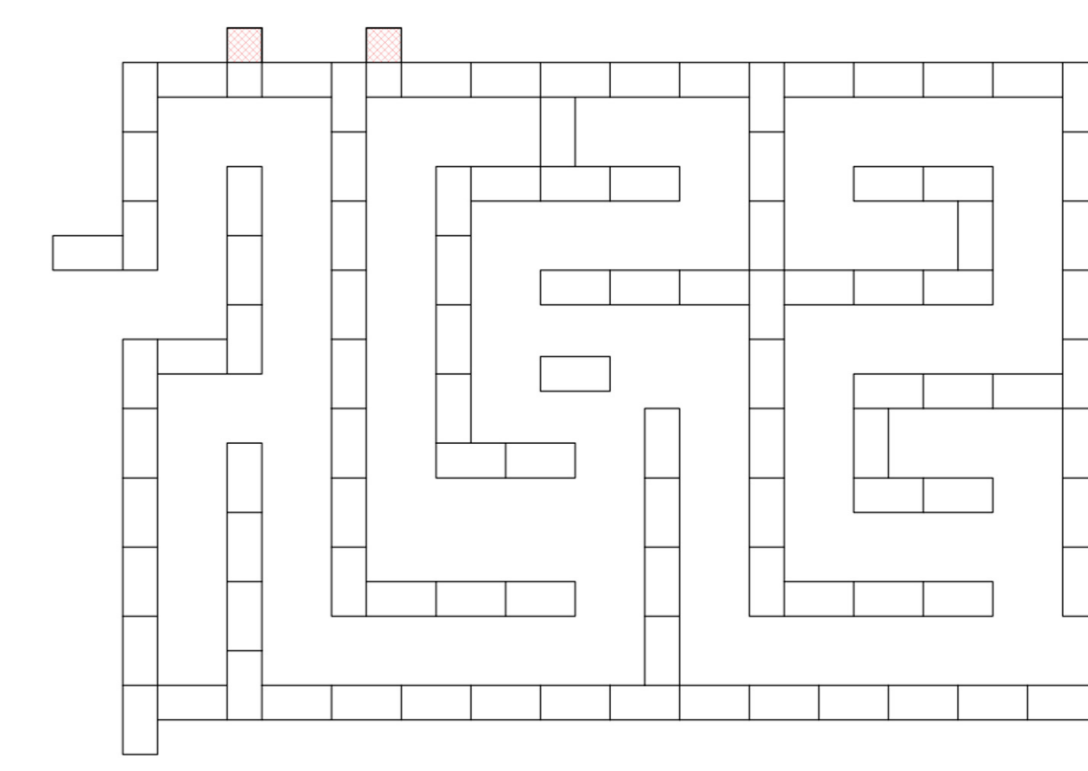

/ ШЕМА МОНТАЖЕ
 / MONTAGE SCHEME

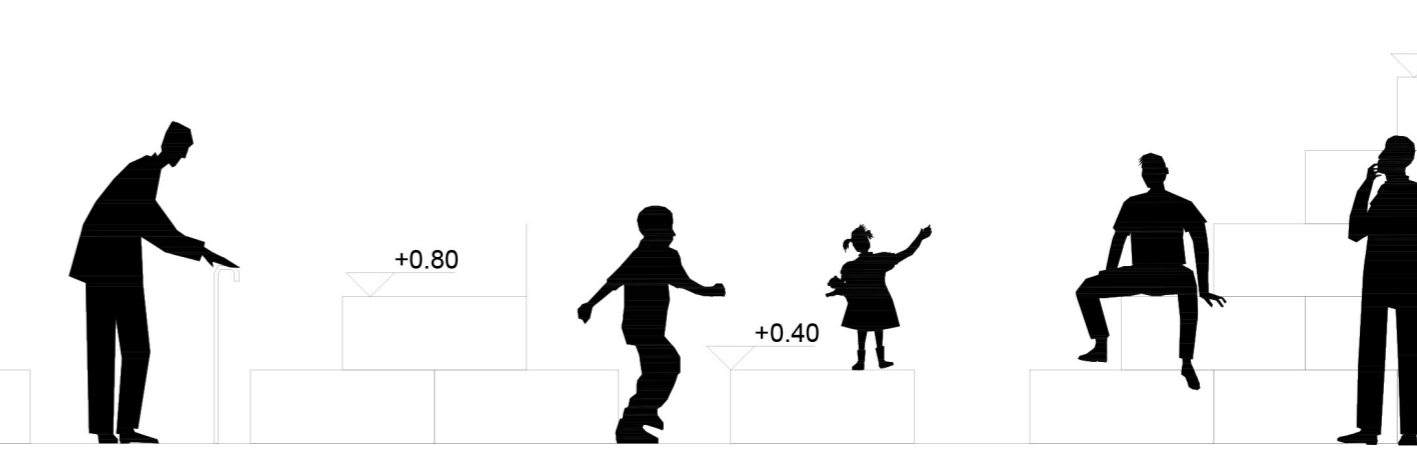

/ ЗАХВАЉУЈУЋИ ЗИДОВИМА РАЗЛИЧИТИХ ВИСИНА, HAY MAZE JE POGODAN ZA KORISNIKE RAZLIČITOG UZRASTA. SASTAVLJEN JE OD NISKIH ZIDOVA NA KOJE MOŽETE SESTITI ILI IH PRESKOCITI, I VISOKIM KOJIMA SE ISPLUĆAVA OSNOVNA FUNKCIЈА LAVIRINTA.

/ THANKS TO THE WALLS OF DIFFERENT HEIGHTS, HAY MAZE IS SUITABLE FOR USERS OF DIFFERENT AGES. IT IS COMPOSED OF LOW WALLS THAT YOU CAN SIT ON OR JUMP OVER, AND HIGH WALLS THAT FULFILL THE PRIMARY FUNCTION OF A MAZE.

PUBLIC SPACE / TEMPORARY INSTALLATIONS

RO Spațiu public / Instalații temporare HU Közterület / Ideiglenes telepítések SRB Javni prostor / Privremene instalacije

AUTHOR(S)/TEAM REPRESENTATIVES
 **Autor(i)/Reprezentanți echipă **Szerezők/A csapat képviselői **Autori/ Predstavnici tima

Manja Pavlović

COLLECTIVE/OFFICE
 **Colectiv/birou **Kollektiva/iroda **Kolektiv/biro

Arhitektonski centar Kiparh

CO-AUTHORS/TEAM MEMBERS
 **Co-autori/membrii echipei **Társzerzők/csapattagok **Koutori/članovi tima

Sara Parezanović, Aleksandra Janjić, Kristina Komlenić, Anđela Ivanović, Rastko Šundić, Aleksandar Stamenković

EXTERNAL COLLABORATORS
 **Colaboratori externi **Külső munkatársak **Spoljni saradnici

JP Hipodrom Beograd Sfera Podkast Portal Gradnja.rs Silosi Beograd Gaia Pokret Kiparh architects

CLIENT
 **Client **Ügyfél **Klijent

/

PROJECT TITLE
 **Titlul proiectului în Engleză **A projekt címe **Naslov projekta

Hay maze

BUILDER
 **Construcător **Építész **Graditelj

Arhitektonski centar Kiparh

PROJECT LOCATION
 **Locația proiectului **Projekt helyszíne **Lokacija projekta

Belgrade, Serbia

PHOTO CREDITS
 **Credite foto **Fényképek hitelei **Foto krediti

Papilon company

PROJECT DESCRIPTION IN MOTHER TONGUE
 **Descrierea proiectului în limba maternă **A projekt leírása a pályázó anyanyelvén **Opis projekta na maternem jeziku

Projekat "Hay Maze" predstavlja efemernu arhitekturu koja kroz inovativni pristup objedinjuje održivost, funkcionalnost i društvenu interakciju. Razvijen je kao lavirint, mesto okupljanja i izložbeni prostor na Beogradskom hipodromu, naglašavajući javnu funkciju prostora za sve uzraste. Korišćenje bala slame kao gradivnog materijala ukazuje na ekološku svest i integraciju s prirodom, služeći kao platforma za društvenu inkluziju i edukaciju. Projekat ističe participativnu arhitekturu i uključivanje zajednice, promovišući arhitekturu kao sredstvo za unapređenje javnih prostora i zajedničkog života. Hay Maze paviljon je privremeni objekat koji služi kao lavirint, mesto okupljanja i izložbeni prostor. Različite visine zidova omogućavaju korišćenje za sve uzraste, a sastavljen je od niskih zidova za sedenje ili preskakanje i visokih zidova za funkciju lavirinta. Integrisan je u urbano i prirodno okruženje Beogradskog hipodroma korišćenjem ekoloških materijala i kontrastom boja na zeleno livadi. Hay Maze je montažno-demontažni objekat koji ne ostavlja trag na lokaciji nakon uklanjanja. Prostorno je usklađen s kontekstom lokacije, prateći njenu podužnu osu, a ulazi i izlazi su produžetak postojećih ruta

korisnika. Izbor materijala bio je ključan, sa idejom da se slama nakon demontaže ponovo iskoristi na lokaciji ili u blizini. Slama je donirana sportskom udruženju za potrebe konja, čime je smanjena energija za transport i ostvarena ekološka komponenta projekta. Korisnici često arhitekturu povezuju s objektima zatvorenim zidovima i krovom, od trajnih materijala. Hay Maze proširuje ovu percepciju, naglašavajući osećanja, funkcije, sećanja i emocije koje prostor izaziva. Centralna zona lavirinta formira trg, otvoren prostor u poluzatvorenom prostoru, sa zidovima od slame. Otvori u pregradama i različite visine zidova stvaraju igru svetlosti i senke, dodajući slojevitost prostoru. Tekstura slame doprinosi vizuelnoj atraktivnosti i senzornom iskustvu korisnika, uz miris i dodir slame. Kao izložbeni prostor, grubi zidovi od slame kontrastno ističu glatke površine papira, prirodno naglašavajući izložene projekte bez dodatne rasvete. Hay Maze je rezultat timskog rada dece i odraslih sa zajedničkim ciljem unapređenja i razvoja građane sredine i arhitekture kao struke, umetnosti i nauke. Kroz saradnju različitih sfera struke, deci je pokazana važnost podrške i saradnje među kolegama.

The "Hay Maze" project represents ephemeral architecture that combines sustainability, functionality, and social interaction through an innovative approach. Developed as a maze, gathering place, and exhibition space at the Belgrade Hippodrome, it emphasizes the public function of a space for all ages. Using straw bales as the main building material highlights ecological awareness and integration with nature, serving as a platform for social inclusion and education. The project emphasizes participatory architecture and community involvement, promoting architecture as a means to improve public spaces and communal life. The Hay Maze pavilion is a temporary structure serving as a maze, gathering place, and exhibition space. The varying wall heights accommodate users of all ages, with low walls for sitting or climbing and high walls for the maze function. Integrated into both the urban and natural environment of the Belgrade Hippodrome, it uses ecological materials and color contrast to stand out on the green meadow. The Hay Maze is a modular, temporary structure that leaves no trace after removal. It is spatially aligned with the context of its location, following the longitudinal axis of the site, with entrances and exits extending existing user routes. The choice of materials was crucial,

with the idea that the straw would be repurposed on or near the site after dismantling. The straw was donated to a sports association for horse needs, reducing energy for transport and fulfilling the project's ecological component. Users often associate architecture with enclosed buildings of permanent materials. Hay Maze expands this perception, emphasizing feelings, functions, memories, and emotions evoked by the space. The central zone of the maze forms a square, an open space within a semi-enclosed area with straw walls. Openings in the partitions and varying wall heights create a play of light and shadow, adding spatial layers. The texture of the straw enhances visual appeal and sensory experience, with the smell and touch of the straw enriching the users' experience. As an exhibition space, the rough straw walls contrast with the smooth surfaces of paper, naturally highlighting the displayed projects without additional lighting. It is the result of teamwork between children and adults with a common goal of improving and developing the built environment and architecture as a profession, art, and science.